

VCRI - MATTALA / Mattala Rajapaksa Intl Airport**VCRI AD 2.1 AERODROME LOCATION INDICATOR AND NAME**

1.	Location Name	Mattala
2.	Name of Aerodrome	Mattala Rajapaksa International
3.	ICAO Location Indicator	VCRI

VCRI AD 2.2 AERODROME GEOGRAPHICAL AND ADMINISTRATIVE DATA

1.	ARP co-ordinates and site at AD	061704.08N 0810726.86E (RWY Mid Point)
2.	Direction and distance from (city)	9NM, Bearing 001 ⁰ , from Hambantota town.
3.	Elevation / Reference temperature	48M / 32.5 ⁰ C
4.	Geoid Undulation at AD ELEV PSN	(-)97M
5.	MAG VAR / Annual change	2 ⁰ W (2017) / Negligible
6.	AD Administration, address, telephone, Tele fax, AFS	Airport & Aviation Services (S. L) (Private)Ltd, Mattala Rajapaksa International Airport, Mattala, Sri Lanka. Tel : +94-47-2031100 Fax : +94-47-2031130 AFS : VCRIYDYX e-mail : ammria@airport.lk
7.	Types of traffic permitted (IFR/VFR)	IFR / VFR
8.	Remarks	Nil

VCRI AD 2.3 OPERATIONAL HOURS.

1.	Aerodrome Administration	H24
2.	Customs and Immigration	H24
3.	Health and Sanitation	H24
4.	AIS Briefing Office	H24
5.	ATS Reporting Office	H24
6.	Met Briefing Office	H24
7.	Air Traffic Services	H24
8.	Fuelling	H24
9.	Handling	H24
10.	Security	H24
11.	Remarks	Nil

VCRI AD 2.4 HANDLING SERVICES AND FACILITIES

1.	Cargo Handling Facilities	Available for all anticipated requirements
2.	Fuel / Oil Types	Fuel : Lanka Aviation Turbine Fuel (Jet A-1) - No limitation. Aviation Gasoline (AVGAS 100LL) - in 200ltr barrels on request
3.	Fuelling Facilities / Capacity	One No. 'BENZE/ROHR' 19,000 IG 600GPM Refueller One No. 'BENZE'/Fluid Transfer 6500 IG 600 GPM.
4.	Hanger space for visiting aircraft	Nil
5.	Repair facilities for visiting aircraft	Line Maintenance Facility
6.	Remarks	Nitrogen available. Basic transit handling, Other Facilities with prior arrangements with SriLankan Airlines.

VCRI AD 2.5 PASSENGER FACILITIES

1.	Hotels	Hotel counters available in the arrival lobby.
2.	Restaurants	Available in the public and transit area.
3.	Transportation	Taxis to city/Rent a Car service, Travel agents
4.	Medical Facilities	First Aid & Ambulance available at airport. Hambantota Base Hospital - 27Km
5.	Bank and Post Office	Available at Airport
6.	Tourist Office	Available at Airport
7.	Remarks	Snack bars, shops available in the public lobby area & Transit. Bond Baggage, Left Luggage facility available

VCRI AD 2.6 RESCUE AND FIRE FIGHTING SERVICES

1.	AD category for fire fighting	Cat 10 (No facilities for foaming of RWY)
2.	Rescue equipment	Adequate rescue and fire fighting vehicles, equipment and personnel available
3.	Capability for removal of disabled aircraft	Hydraulic Jacks, Max. A320

VCRI AD 2.7 SEASONAL AVAILABILITY – CLEARING

AD Available throughout the year

VCRI AD 2.8 APRONS, TAXIWAYS AND CHECK LOCATIONS DATA

1.	Apron surface and strength	Concrete, PCN86/R/B/W/T
2.	Taxiway width, Surface and Strength	TWY A – width 25M Asphalt , Right angle exit TWY, Strength PCN71/F/B/W/T (17.5M shoulders either side), TWY B – width 15M, Asphalt, Right angle exit TWY, Strength PCN71/F/B/W/T (5M shoulders either side)
3.	ACL location and elevation	At Apron, 50M
4.	INS check points	See Aircraft Parking / Docking chart (page VCRI AD 2-25)
5.	VOR check points	On TWY A - 231.5 ⁰ R MTL , 1.54 DME On TWY B - 232.0 ⁰ R MTL, 1.28 DME
6.	Remarks	Nil

VCRI AD 2.9 SURFACE MOVEMENT GUIDANCE AND CONTROL SYSTEM AND MARKINGS

1.	Use of aircraft stand ID signs TWY guide lines and visual docking/parking guidance system of aircraft stands:	TWY guidance system : Nose wheel guidance on TWYs and Apron. Indicators and ground signalling systems: WDI - Lighted TWY guidance indicators - Lighted Apron guidance indicators - Not Lighted
2.	RWY and TWY markings and LGT:	RWY Centreline lights : Variable White from THR to the point 900M from RWY END; ALTN Red and Variable White from 900M to 300M from the RWY END; and Red from 300M to the RWY END. RWY Edge lights : Bi-directional elevated White/Amber Threshold lights : Inset Green at both RWY ends Touchdown Zone lights : Nil RWY End lights : Inset RED at Both ENDS TWY lights : Blue elevated Marking Aids : RWY designation, RWY Centreline, RWY edge, TWY centreline, TWY edge, RWY Ends, Touchdown Zone, Fixed distance, TORA signs, Apron guide lines, Threshold Marking, Enhanced Taxiway Marking, Aiming point, Runway Turn Pad marking, Runway Holding Position Marking.
3.	Stop Bars	Nil
4.	Remarks	Nil

VCRI AD 2.10 AERODROME OBSTACLES

In approach /TKOF areas			In circling area at AD		
RWY / Area affected	Obstacle type Elevation Marking/LGT	Co-ordinates	Obstacle type Elevation Marking/LGT	Co-ordinates	Remarks.
a	b	c	a	b	Nil

Obstacles in the APCH / TKOF areas, Circling area and at the aerodrome are shown on the AOC and IAC

VCRI AD 2.11 METEOROLOGICAL INFORMATION PROVIDED

1.	Associated MET Office	MATTALA/ Mattala Rajapaksa Intl. Airport
2.	Hours of Service MET Office outside hours:	H24 -
3.	Office responsible for TAF preparation: Period of validity.	MATTALA/ Mattala Rajapaksa Intl. Airport, 30Hrs
4.	Type of landing forecast intervals of Issuance	TREND, ½ hr
5.	Briefing/Consultation provided	P,T,D,U,C
6.	Flight Documentation: Language(s) used:	C, TB English
7.	Charts and other information available for briefing consultation	S,P,U,W
8.	Supplementary equipment available for providing information	SADIS system, GTS System, AWOS, WXR, APT
9.	ATS Units provided with information	Colombo FIC, RCC, TWR
10.	Additional information	Tel : 94 47 2030199 Fax : 94 47 2030199 AFS : VCRIYMYX e-mail : met.mria@airport.lk

P - Personal consultation / Prognostic upper air chart
T - Telephone
C - Charts
D - Self Briefing
TB - Tabular forms
U - Upper air analysis (current chart)
W - Significant weather chart
S - Surface analysis (current)
WXR - Weather radar
APT - Receiver for Satellite cloud picture.

VCRI AD 2.12 RUNWAY PHYSICAL CHARACTERISTICS

Designation RWY NR.	TRUE BRG	Dimensions of RWY (M)	Strength (PCN) and surface of RWY and SWY	THR Co-ordinates
1	2	3	4	5
05	45.80 ⁰ GEO	3500 X 60	PCN 71/F/B/W/T Asphalt	061624.53N 0810645.88E GUND (-)97.5M
23	225.80 ⁰ GEO			061743.63N 0810807.84E GUND (-)97.5M
Designation RWY NR.	THR elevation and highest elevation of TDZ of Precision APP RWY	Slope of RWY / SWY	Dimensions of SWY (M)	Dimensions of CWY (M)
	6	7	8	9
05	THR ELEV 41.5M	0.2 % Up	Nil	300 X 150
23	THR ELEV 48.5M	0.2 % Down	Nil	300 X 150
Designation RWY NR.	Strip dimensions (M)	Obstacle Free Zone	Remarks	
	10	11	12	
05	3620 X 300	Nil	RESA - RWY 05 - 240(M) X 150(M) RWY 23 - 240(M) X 150(M)	
23		Nil		

VCRI AD 2.13 DECLARED DISTANCES

Designation RWY NR	TORA (M)	TODA(M)	ASDA(M)	LDA(M)	Remarks
1	2	3	4	5	6
05	3500	3800	3500	3500	Nil
23	3500	3800	3500	3500	

VCRI AD 2.14 APPROACH AND RWY LIGHTING

RWY	APCH LGT Type, Length, INTST	THR LGT Colour, WBAR	VASIS (MEHT) PAPI	TDZ LGT Spacing, Colour, INTST	RWY Centreline LGT Length, Spacing, Colour, INTST	RWY Edge LGT Length, Spacing, Colour, INTST	RWY End LGT Colour, WBAR	SWY LGT Length (M) Colour	Remarks
1	2	3	4	5	6	7	8	9	10
05	Simple approach Lighting System 420m, Five steps brightness change	GREEN -	PAPI both sides 3 ⁰ MEHT 22.53M	N/A	3500M, 15M, (0M -2600M) - Variable WHITE. (2600M – 3200M) - Alternate RED/WHITE. (3200M-3500M) - RED , LIH	3500M, 60M, (0M-2900M) - WHITE (2900M - 3500M) - AMBER, LIH	RED -	Nil	Nil
23	ICAO CAT I Precision Approach Lighting system. Five cross bars. Five steps brightness change	GREEN GREEN	PAPI both sides 3 ⁰ MEHT 19.53M	N/A	3500M, 15M, (0M -2600M) - Variable WHITE. (2600M – 3200M) - Alternate RED/WHITE. (3200M-3500M) - RED , LIH	3500M, 60M, (0M-2900M) - WHITE (2900M - 3500M) - AMBER, LIH	RED -	Nil	Nil

VCRI AD 2.15 OTHER LIGHTING, SECONDARY POWER SUPPLY

1.	ABN / IBN location, characteristics and hours of operation	ABN : At TWR Building FLG Altn (12) W & (12) G EV 2.5 SEC, HO IBN : Nil
2.	LDI location and LGT Anemometer location and LGT	Nil Anemometer : Not lighted
3.	TWY edge and centreline lighting	Edge : BLUE Centreline : Nil
4.	Secondary power supply / switch over time	Switch over time : 15 Sec
5.	Remarks.	Nil

VCRI AD 2.16 HELICOPTER LANDING AREA

Not Specified

VCRI AD 2.17 ATS AIRSPACE

1.	Designation and lateral limits	MATTALA - CTR. An airspace bounded laterally by; i) North-Western arc of the circle of 10NM radius centred on VCRI ARP coords; 061704.08N 081 07 26.86E. ii) South-Eastern arc of the circle of 10NM radius centred on Wirawila (VCCW) RWY mid-point cords: 061516.82N 0811407.11E, and; iii) two tangents drawn between the arcs of circles referred to i) and ii) above.
2.	Vertical Limits.	SFC to 4000FT ALT
3.	Airspace Classification	C
4.	ATS Unit Call sign Language(s)	Mattala Tower English
5.	Transition Altitude	11000FT
6.	Remarks.	Wirawila CTR (Ref. AIP page VCCW AD 2-3, item VCCW AD 2.17 ATS AIRSPACE) has been merged into MATTALA CTR and the Airspace Classification upgraded from Class D to Class C.

VCRI AD 2.18 ATS COMMUNICATION FACILITIES

Service Designation	Call Sign	Frequency	Hours of Operation	Remarks
1	2	3	4	5
TWR / APP	Mattala Tower	119.85MHz *124.35MHz	H24	* - Standby Frequency
TWR/ SMC	Mattala Ground	121.70MHz		Controlling Authority: AASL

VCRI AD 2.19 RADIO NAVIGATION AND LANDING AIDS

Type of Aid and variation	ID	Frequency / CH	Hours of Operation	Site of Transmitting Antenna Co-ordinates	DME Transmitting Antenna Elevation / Remarks
1	2	3	4	5	6 & 7
DVOR / DME (2°W/2009)	MTL	116.7 MHz / CH 114X	H24	061814.13N 0810839.46E	DME Co-located with DVOR. DME Antenna ELEV: 55.30M
ILS / LLZ RWY 23	IME	109.5 MHz	H24	061617.86N 0810638.97E	ICAO CAT I , EM: A0 / A2
ILS GP RWY 23	-	332.6 MHz	H24	061733.12N 0810803.05E	GP Angle 3 deg , EM A0/A2 Ref. Datum 15.64M (51.3FT)
ILS DME RWY 23	IME	CH 32X	H24	061733.12N 0810803.05E	DME co-located with GP RWY 23 EM: P0 DME Antenna ELEV: 50.65M
MM RWY 23	Dot - dash	75 MHz	H24	061806.22N 0810831.25E	0.70 DME / IME 1.0W EM: A0 / A2

	VCRI AD 2.20 LOCAL TRAFFIC REGULATIONS	7	Special Procedure For Push Back And Start-Up
1.	Airport Regulations	7.1	Aircraft departing VCRI shall adhere to the procedure for push-back and assignment of flight levels.
1.1	AD is restricted to aircraft capable of maintaining two way radio communications with Mattala ATC.	7.2	Assignment of flight levels to departing aircraft shall be made on first-come-first served basis. Aircraft normally will be assigned the level requested unless an alternative level is offered after coordination with the adjacent ATC Centres.
1.2	Local Flying Restrictions	7.3	Pilots shall use the correct phraseology as specified in para 7.4 below when requesting clearance to push-back in order to avoid confusion.
	a). Non-Scheduled and private flights PPR as per para 3 of sub section GEN 1.2	7.4	When an aircraft is ready to push back and start within Five (5) minutes, the Pilot shall notify ATC using the following phraseology.
	b). Pilots intending to conduct local flights are required to obtain prior permission from DGCA.		
	c). Local flights overflying VCRI below 5000FT within 30NM of VCRI AD will be required to use the QNH values issued from Mattala Tower		
2.	Taxing To/From Stands		<ul style="list-style-type: none">- Call sign- Destination- Proposed flight level (in the flight plan) and alternate if any- Parked position- POB- "Ready to push back and start in five minutes"
2.1	Follow ATC instructions. Also see Aerodrome Chart and Aircraft Parking/Docking Chart.		
3	Parking Area For Small Aircraft (General Aviation)	7.5	On receipt of the "ready to push-back and start" call, ATC will advise the pilot of any delay and reason, and after the pre-departure coordination with adjacent centres, the ATC clearance will be issued. An alternate flight level may be given by ATC if the flight-planned level cannot be assigned.
3.1	As specified by ATC.		
4	Parking Area For Helicopters		
4.1	Not specified.		
5	Apron-Taxing During Winter Condition	7.6	Once the ATC clearance is accepted by the pilot; the aircraft must be pushed back within Five (5) minutes. The ATC clearance will be cancelled after five (5) minutes grace period.
5.1	Not applicable.		
6.	Taxing Limitations	7.7	At the end of the push back, the departing aircraft must have all engines started and be ready to taxi immediately, unless otherwise instructed by ATC.
6.1	Taxiway 'B' is the most likely taxiway for light aircraft.	7.8	An ATC clearance once issued to a departing aircraft as per para 7.5 above may be cancelled under the following circumstances:
6.2	Strictly adhere to ATC instructions on taxing for protection from any jet-blast of Turbo-jet aircraft.		

- a). The aircraft is unable to push back still on expiry of the grace period as per para 7.6 unless authorized by ATC.
- b). After pushing back, the pilot advises that the aircraft is returning to the bay.
- c). If the aircraft is unable to commence / continue taxing due to an operational or technical reason.
- 7.9 ATC will inform the aircraft when a clearance is cancelled.
- 7.10 After a cancellation of an ATC clearance already issued, the pilot of such aircraft will follow the same procedure laid down in paras 7.4 to 7.7.
- 8. Aircraft Parking, Marshalling And Towing.**
- 8.1 All aircraft parking bays are allocated by the tower controller with regard to aircraft type involved and the prevailing or anticipated traffic situation.
- 8.2 Only Nose- in parking is permitted
- 8.3 All ARR/DEP aircraft irrespective of their size should make use of Marshalling Services, which will be provided by SriLankan Airlines.
- 8.4 Carriage of tow-bar is mandatory for the following or similar types of aircraft:
IL18 ,IL62, IL76, IL86, AN12, AN26, AN124
- 9. School And Training Flights- Technical Test Flights- Use of Runways**
- 9.1 Training flights and technical test flights necessary for ascertaining the airworthiness of an aircraft shall be conducted only after permission has been obtained from ATC.
- 10. Helicopter Operations**
- 10.1 Engine ground running with rotors turning is not permitted within 200M of other aircraft, Motor vehicles or buildings.
- 10.2 Where surface taxing is involved, existing TWY system is to be utilized. Whenever possible, taxi manoeuvring should be confined to the existing TWY system.
- 11 Light Aircraft Operations**
- 11.1 VFR Operations**
- 11.1.1 Light aircraft operations may be authorized at the discretion of ATC when traffic conditions permit.
- 11.1.2 Light aircraft operations shall be conducted under VFR, within Mattala CTR..
- 11.1.3 Light aircraft not equipped with two-way communication shall not be permitted to operate flights within Mattala CTR..
- 11.1.4 For circuit and landings or local flights of not more than 30 minutes duration, verbal flight notification is acceptable. In such cases, the following information shall be provided to the ATC Tower;
- i. Aircraft identification and type,
 - ii. Name of Pilot
 - iii. Departure Aerodrome & ETD
 - iv. Provisional ETA for VCRI
 - v. Flight duration
 - vi. Area of flight operation.
- 11.2 IFR Operations**
- 11.2.1 Requests for operations under IFR may be approved if the aircraft is suitably equipped for IFR operations and the pilot is appropriately rated.
- 11.2.2 Mattala ATC shall be the final authority in authorizing such operations from the point of view of air traffic.
- 11.3 Cross Country Flights**
- 11.3.1 Pilots of aircraft proceeding on cross country flights departing VCRI and/or expecting to transit Mattala CTR shall flight plan with ATC at least Thirty (30) minutes before the ETD.
- 11.3.2 The flight shall be conducted strictly in accordance with the clearance obtained.

-
- | | |
|--|---|
| <p>12. Removal of Disabled Aircraft From Runways</p> <p>12.1 When an aircraft is wrecked on the runway, it is the duty of the owner or user of such aircraft to have it removed as soon as possible.</p> <p>13. Ground Handling Facilities And Services</p> <p>13.1 Designated Agency:</p> <p>13.1.1 SriLankan Airlines is the designated agency responsible for the provision of ground handling facilities and services for all aircraft operating to / from MATTALA / Mattala Rajapaksa Intl. Airport (VCRI). It is therefore necessary that the operator should arrange with Sri Lankan airlines for the ground handling of aircraft before landing. (website: http://www.srilankan.com/ground-handling/contact-us/ul-contacts.htm) and such arrangement shall be made known to the Director General of Civil Aviation, Sri Lanka .</p> | <p>3. Standard Instrument Departures (SID).</p> <p>3.1 The SIDs shown on pages VCRI AD 2-29 and VCRI AD 2-31 shall be used by the departing IFR flights on RWY 05 and RWY 23 respectively except when otherwise instructed by ATC. Departure clearance will include a reference to the appropriate SID to be followed, if required by ATC.</p> <p>4. Radar Services and Procedures</p> <p>4.1 Radar services will be available above 5000FT for arriving and departing aircraft to/from VCRI including transiting traffic.</p> |
|--|---|
- VCRI AD 2.23 ADDITIONAL INFORMATION**
- Nil

VCRI AD 2.21 NOISE ABATEMENT PROCEDURES

1. It is mandatory requirement to have a Noise Certificate on board of the all aircraft arriving at VCRI

VCRI AD 2.22 FLIGHT PROCEDURES

- 1. **SIDs and STARs**
- 1.1 The SID/STAR specific phraseologies incorporated in PANS-ATM (DOC 4444) Amendment 7-A are adopted as detailed in sub section ENR 1.1, para 19.
- 2. **Standard Terminal Arrival Routes (STAR).**
- 2.1 The STARs shown on **VCRI AD 2-33 and VCRI AD 2-35** shall be used by the arriving IFR flights on RWY 05 and RWY 23 respectively except when otherwise instructed by ATC. Inbound clearance will include a reference to the appropriate STAR to be followed, if required by ATC.

**VCRI AD 2.24 CHARTS RELATED TO MATTALA / MATTALA RAJAPAKSA INTL
AERODROME**

Chart Name	Page
Aerodrome Chart – ICAO	VCRI AD 2 - 23
Aircraft Parking/Docking Chart	VCRI AD 2 - 25
Aerodrome Obstacle Chart Type A – ICAO	VCRI AD 2 - 27
Standard Departure Chart – Instrument (SID) – ICAO – RWY 05	VCRI AD 2 - 29
Standard Departure Chart – Instrument (SID) – ICAO – RWY 23	VCRI AD 2 - 31
Standard Arrival Chart – Instrument (STAR) – ICAO – RWY 05	VCRI AD 2 - 33
Standard Arrival Chart – Instrument (STAR) – ICAO – RWY 23	VCRI AD 2 - 35
Instrument Approach Chart – ICAO - RNP RWY05	VCRI AD 2- 37-39
Instrument Approach Chart – ICAO – RNP RWY23	VCRI AD 2 - 41-43
Instrument Approach Chart – ICAO – ILS / DME RWY 23	VCRI AD 2 - 45
Instrument Approach Chart – ICAO – DVOR / DME RWY 05	VCRI AD 2 - 47
Instrument Approach Chart – ICAO – DVOR / DME RWY 23	VCRI AD 2 - 49

AERODROME CHART - ICAO 06 17 04N 081 07 27E ELEV 48.3m TWR 119.85 SMC 121.70 MATTALA / MATTALA RAJAPAKSA INTL. AIRPORT

RWY	DIRECTION	THR	BEARING STRENGTH
05	48°	06 16 24.53N 081 06 45.88E	PCN 71/F/B/W/T
23	228°	06 17 43.62N 081 08 07.84E	
APRONS			See page VCRI AD2-25

TWY A-25 m wide (17.5 m shoulders either side), TWY B-15 m wide (5 m shoulders either side)

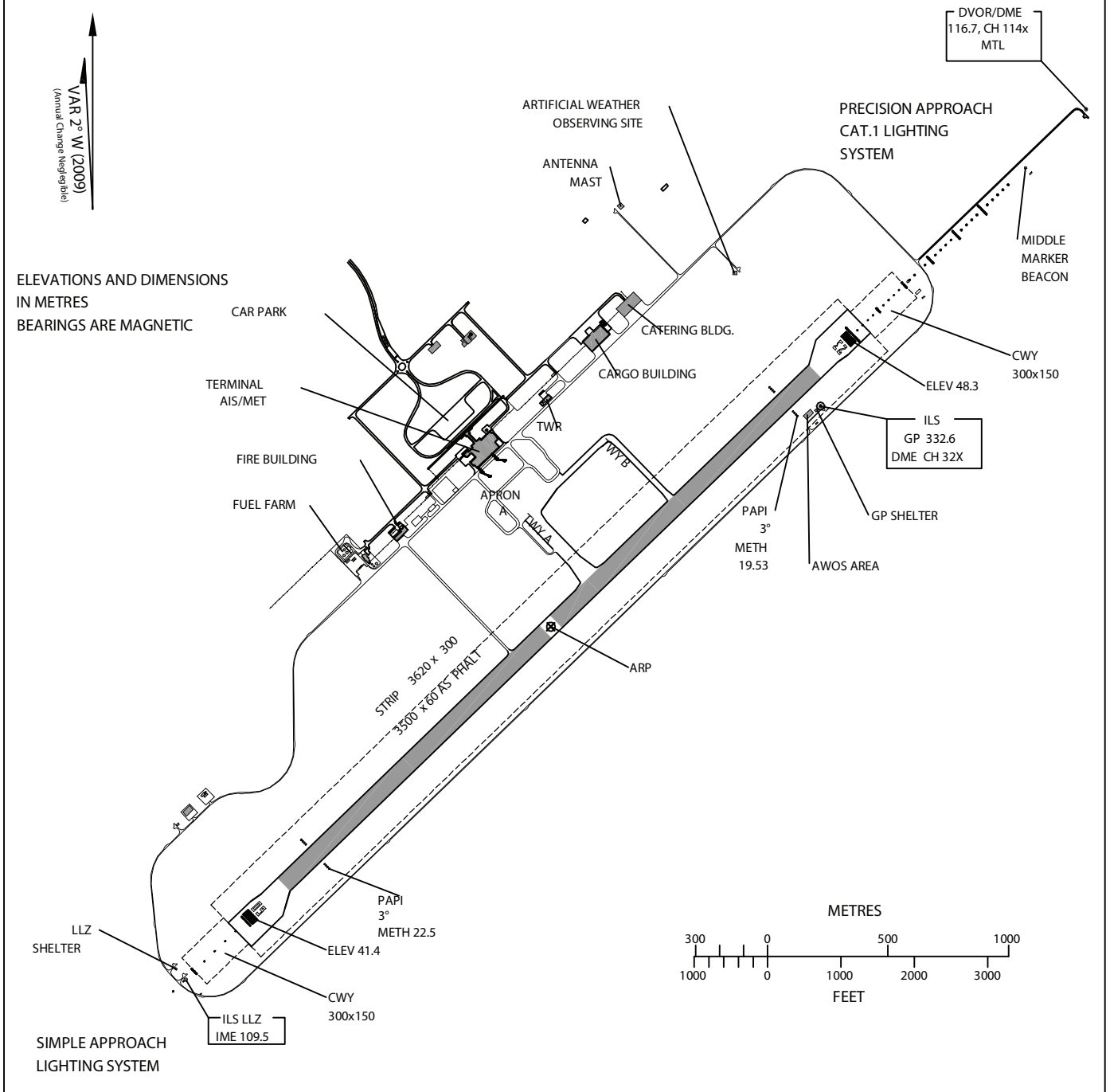

MARKING AIDS RWY 05/23 AND EXIT TWY

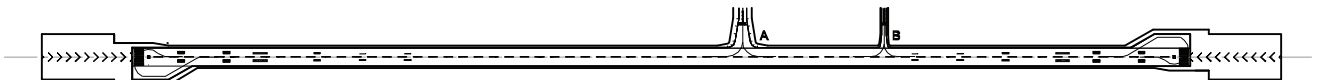

LIGHTING AIDS RWY 05/23 AND EXIT TWY

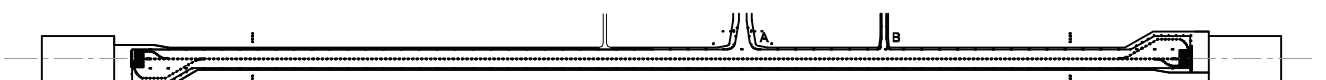

AIRCRAFT PARKING/
DOCKING CHART - ICAO

APRON ELEV
50.0 m

TWR 119.85
SMC 121.70

MATTALA / MATTALA RAJAPAKSA INTERNATIONAL
AIRPORT

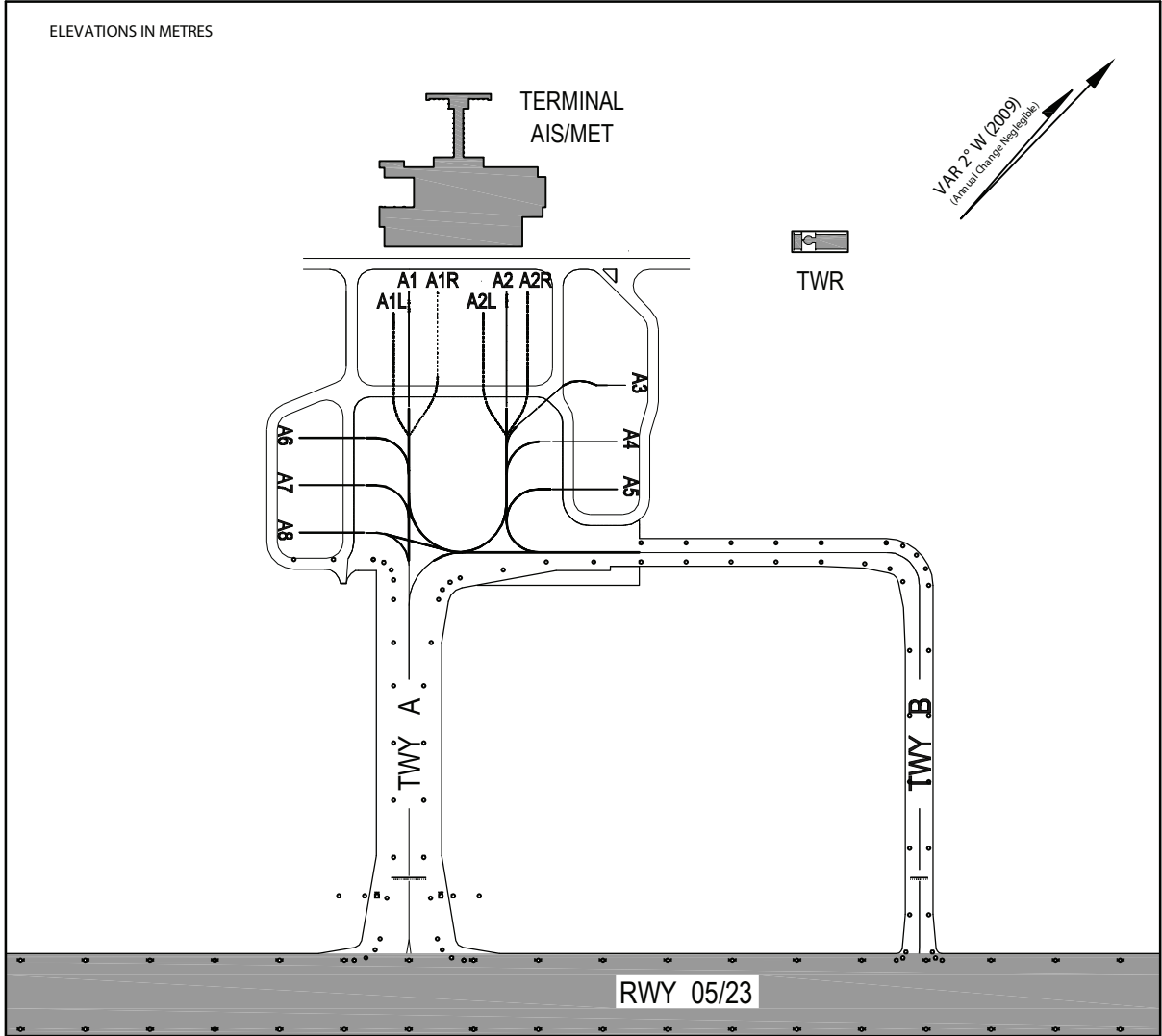

NOT TO SCALE

LEGEND	
AIRCRAFT STAND	A1
TAXIWAY LIGHTS	o

TWY A - 25 M (17.5 M shoulders either side) - PCN 71/F/B/X/T
TWY B - 15 M (5 M shoulders either side) - PCN 71/F/B/X/T

PARKING STAND	INS COORDINATES FOR AIRCRAFT STANDS	BEARING STRENGTH
APRON A		
A1L	06 17 24.40N 081 07 18.79E	PCN 86/R/B/W/T
A1	06 17 25.18N 081 07 18.67E	PCN 86/R/B/W/T
A1R	06 17 26.04N 081 07 19.02E	PCN 86/R/B/W/T
A2L	06 17 26.22N 081 07 20.73E	PCN 86/R/B/W/T
A2	06 17 27.34N 081 07 20.63E	PCN 86/R/B/W/T
A2R	06 17 27.90N 081 07 20.93E	PCN 86/R/B/W/T
A3	06 17 28.03N 081 07 25.44E	PCN 86/R/B/W/T
A4	06 17 26.63N 081 07 26.40E	PCN 86/R/B/W/T
A5	06 17 25.62N 081 07 27.38E	PCN 86/R/B/W/T
A6	06 17 19.65N 081 07 19.05E	PCN 86/R/B/W/T
A7	06 17 18.64N 081 07 20.03E	PCN 86/R/B/W/T
A8	06 17 17.63N 081 07 21.00E	PCN 86/R/B/W/T

PASSENGER BOARDING BRIDGES AVBL
AT PARKING STANDS A1 AND A2

MAGNETIC VARIATION 2°W - 2009

MATTALA / MATTALA RAJAPAKSA INTERNATIONAL AIRPORT
SRI LANKA

AERODROME OBSTACLE CHART - ICAO TYPE A (OPERATING LIMITATIONS)

DIMENSIONS AND ELEVATION IN METRES

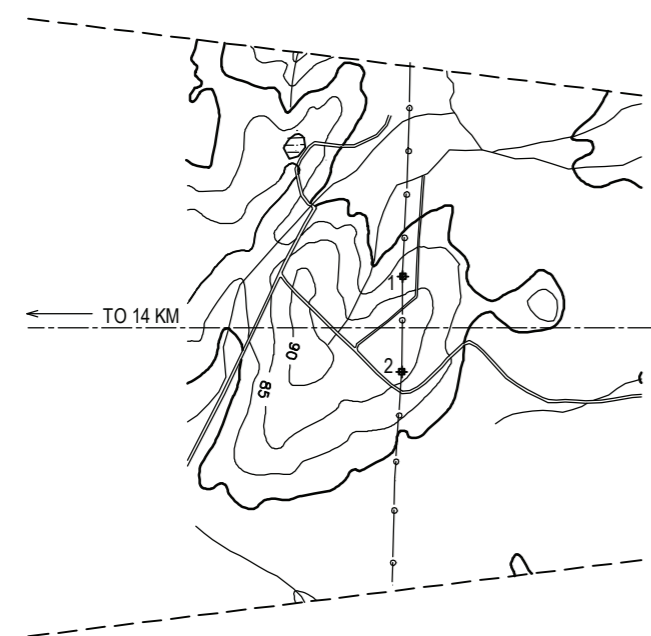
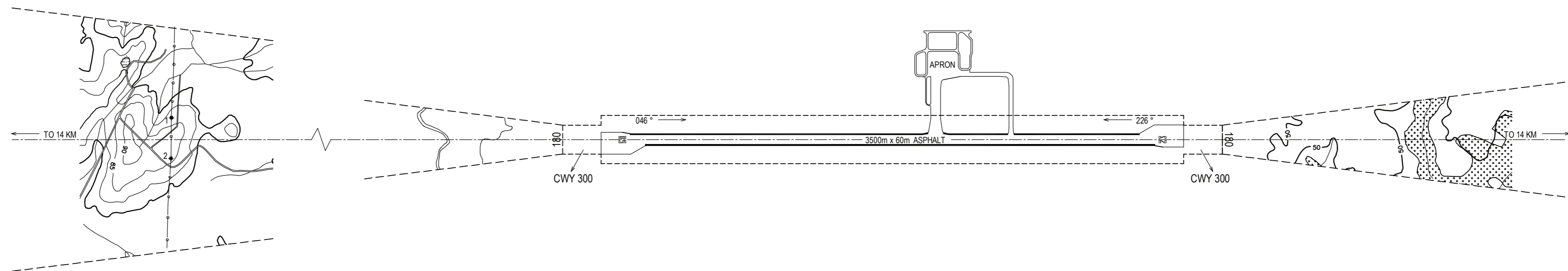
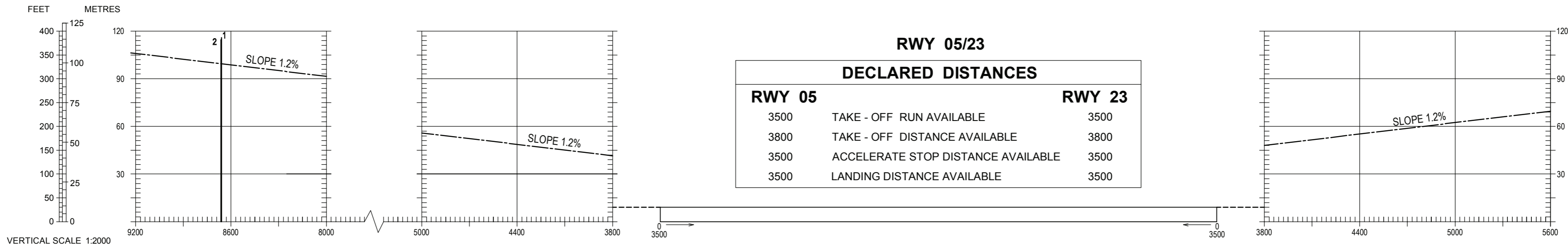

LEGEND	
IDENTIFICATION NUMBER	8
INDEX CONTOUR	—
INTERMEDIATE CONTOUR	—
ROAD	—
ROCK	—
STREAM	—
TANK	—
FOREST	—
POWER LINE	—

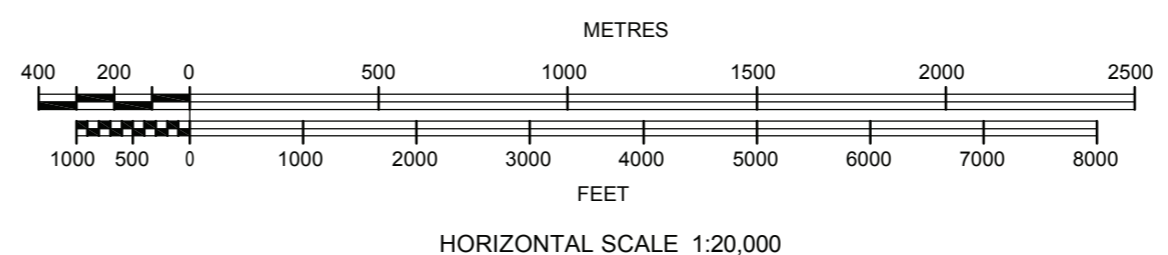

AMENDMENT RECORD		
NO	DATE	ENTERED BY

Date of Survey - 09 November 2012

Drg. NO. - AASL/HIA/2690101

STANDARD ARRIVAL CHART-
INSTRUMENT (STAR)-ICAO

TRANSITION ALTITUDE
11000 FEET

APP 124.35
TWR 119.85
121.70

MATTALA/Mattala Rajapaksa
Intl. Airport (VCRI)
RWY 05

HG1C HK1C HH1C HA1C HC1C

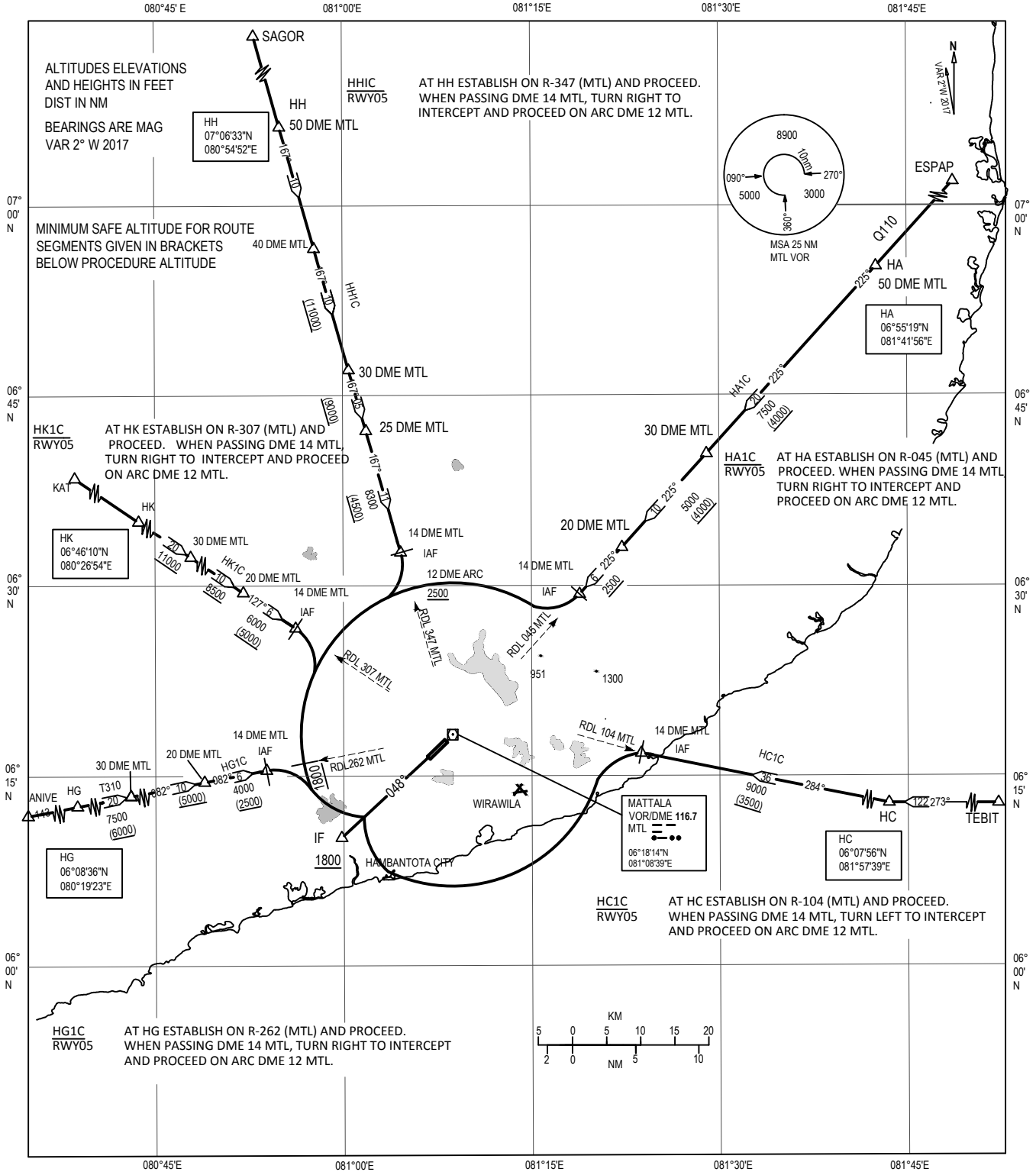

Changes : way point "DABAR " renamed as " SAGOR "

STANDARD ARRIVAL CHART-
INSTRUMENT (STAR)-ICAO

TRANSITION ALTITUDE
11000 FEET

APP 124.35
TWR 119.85
121.70

MATTALA/Mattala Rajapaksa
Intl. Airport (VCRI)
RWY 23
HG1D HK1D HH1D HA1D HC1D

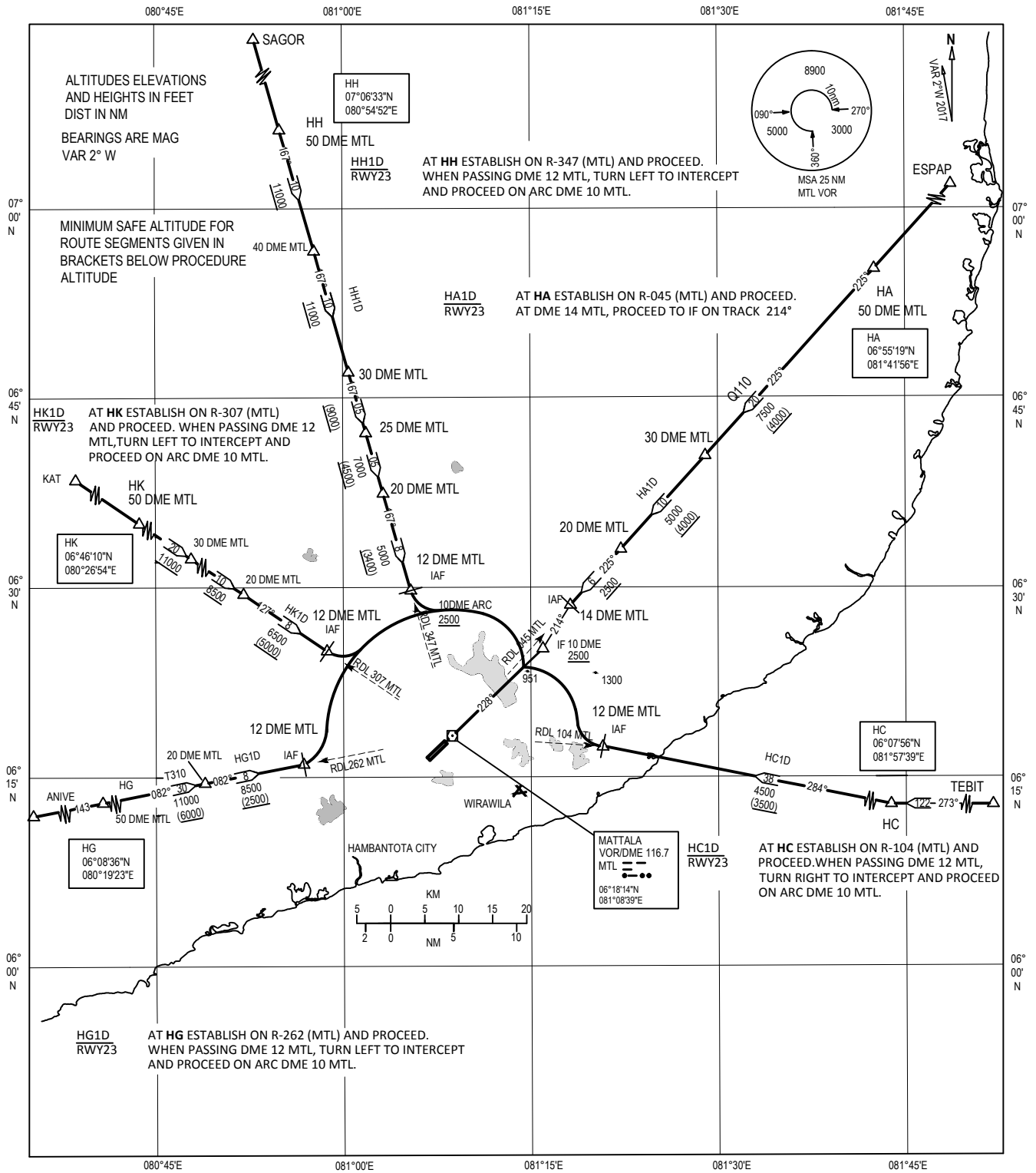

Changes : way point "DABAR " renamed as " SAGOR"

**INSTRUMENT APPROACH
CHART - ICAO**

AD ELEV 159ft
HEIGHTS RELATED TO
THR RWY05 ELEVATION 136ft

Colombo 132.4 120.9
Director
Mattala 119.85 124.35
Tower
SMC 121.7

MATTALA/ Mattala Rajapaksa Intl.(VCRI)

RNP RWY05

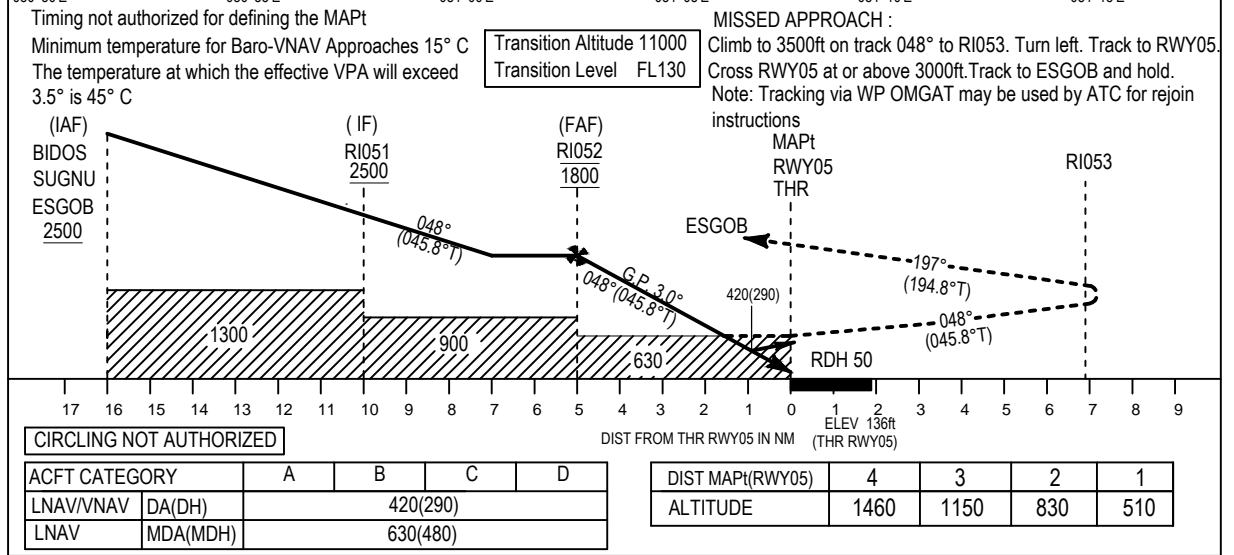
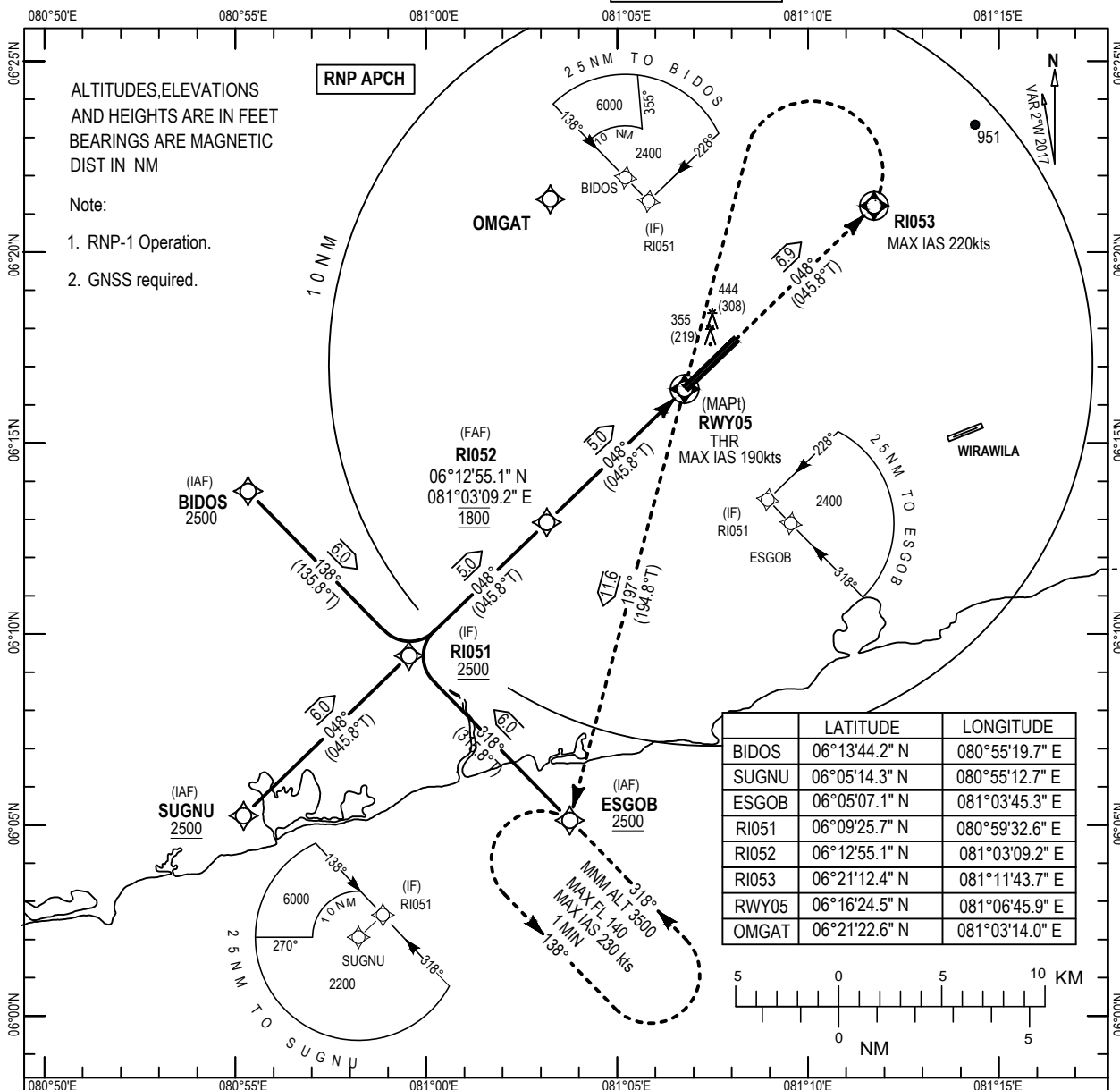

CODING TABLE FOR RNP APCH RWY 05

Segment	FIX	Path Term.	WP	FO	Course/Track ° Mag (°T)	Mag Var.	Distance (NM)	Turn Direction	Altitude (ft)	Max Speed (IAS/kt)	VPA / RDH	NAV Specs
Transition	IAF	IF	ESGOB	-	318 (315.8)	+2.0	6.0	-	+2500	-	-	RNP APCH
	IAF	IF	BIDOS	-	138 (135.8)	+2.0	6.0	-	+2500	-	-	RNP APCH
	IAF	IF	SUGNU	-	048 (045.8)	+2.0	6.0	-	+2500	-	-	RNP APCH
	IF	TF	RI051	-	-	+2.0	-	-	+2500	-	-	RNP APCH

Segment	FIX	Path Term.	WP	FO	Course/Track ° Mag (°T)	Mag Var.	Distance (NM)	Turn Direction	Altitude (ft)	Max Speed (IAS/kt)	VPA/ RDH	NAV Specs
Approach	IF	TF	RI051	-	048 (045.8)	+2.0	5.0	-	+2500	-	-	RNP APCH
	FAF	TF	RI052	-	048 (045.8)	+2.0	5.0	-	@1800	-	-3.0/50	RNP APCH
	MAPT	TF	RWY05	Y	048 (045.8)	+2.0	6.9	-	+630	190	-	RNP APCH
	MATP	CF	RI053	Y	-	+2.0	-	-	-	220	-	RNP APCH
	WP	TF	RWY05	Y	197 (194.8)	+2.0	11.6	-	+3000	-	-	RNP APCH
	MAHF	TF	ESGOB	-	-	+2.0	-	-	+3500	230	-	RNP APCH

Note : Tracking via waypoint OMGAT to rejoin IAF may be used by ATC for aircraft, as an alternate to Missed Approach Procedure.

Path Descriptor	Fix Identifier (WP)	Inbound Course M°(T°)	Leg Distance (NM or min.)	Turn Direction (L/R)	Minimum Altitude (ft)	Maximum Altitude (ft)	IAS (kt)	Magnetic Variation +/- (°)	NAV. Spec.
Hold	ESGOB	318	1 min.	L	3500	14000	230	+2	RNP

**INSTRUMENT APPROACH
CHART - ICAO**

AD ELEV 159 ft
HEIGHTS RELATED TO
THR RWY23 ELEVATION 159ft

Colombo Director	132.4	120.9
Mattala Tower SMC	119.85	124.35
121.7		

**MATTALA / Mattala Rajapaksa Intl. (VCRI)
RNP RWY 23**

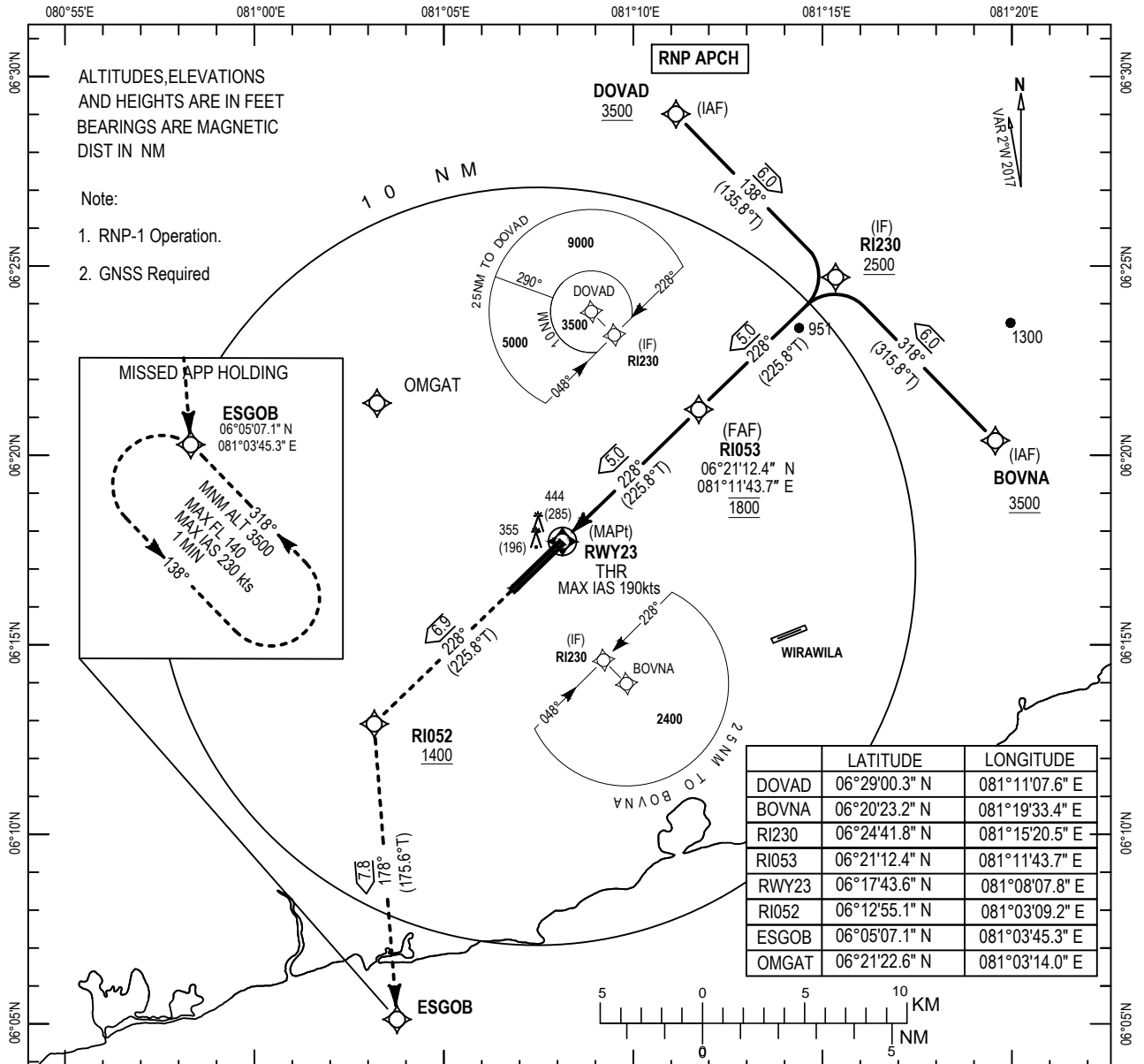

MISSED APPROACH :
Climb to 3500ft on track 228° to RI052. Track to ESGOB and hold.
Note: Tracking via OMGAT may be used by ATC for rejoin instructions

Transition Altitude 11000
Transition Level FL130

Timing not authorized for defining the MAPt
Minimum temperature for Baro-VNAV approaches 15° C
The temperature at which the effective VPA will exceed 3.5° is 45° C (IAF)

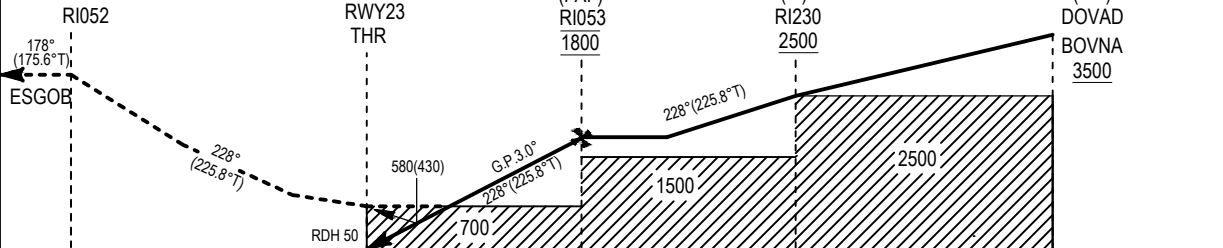

CIRCLING NOT AUTHORIZED				
ELEV 159ft (THR RWY23)				
OCA/OCH				
ACFT CATEGORY	A	B	C	D
LNAV/VNAV DA(DH)		580(430)		
LNAV MDA(MDH)		700(550)		

DIST MAPt(RWY23)	4	3	2	1
ALTITUDE	1490	1170	850	530

CODING TABLE FOR RNP APCH RWY 23

Segment	FIX	Path Term.	WP	FO	Course/Track ° Mag (°T)	Mag Var.	Distance (NM)	Turn Direction	Altitude (ft)	Speed (IAS/kt)	VPA/RDH	NAV Specs
Transition	IAF	IF	DOVAD	-	138 (135.8)	+2.0	6.0	-	+3500	-	-	RNP APCH
	IAF	IF	BOVNA	-	318 (315.8)	+2.0	6.0	-	+3500	-	-	RNP APCH
	IF	TF	RI230	-	-	+2.0	-	-	+2500	-	-	RNP APCH

Segment	FIX	Path Term.	WP	FO	Course/Track ° Mag (°T)	Mag Var.	Distance (NM)	Turn Direction	Altitude (ft)	Speed (IAS/kt)	VPA/RDH	NAV Specs
Approach	IF	TF	RI230	-	228 (225.8)	+2.0	5.0	-	+2500	-	-	RNP APCH
	FAF	TF	RI053	-	228 (225.8)	+2.0	5.0	-	@1800	-	-3.0/50	RNP APCH
	MAPT	TF	RWY23	Y	228 (225.8)	+2.0	6.9	-	+700	190	-	RNP APCH
	MATP	CF	RI052	-	178 (175.6)	+2.0	7.8	-	+1400	-	-	RNP APCH
	MAHF	TF	ESGOB	-	-	+2.0	-	-	-	230	-	RNP APCH

Note :

Tracking via waypoint OMGAT to rejoin IAF may be used by ATC for aircraft, as an alternate to Missed Approach Procedure.

Path Descriptor	Fix Identifier (WP)	Inbound Course M°(T°)	Leg Distance (NM or min.)	Turn Direction (L/R)	Minimum Altitude (ft)	Maximum Altitude (ft)	IAS (kt)	Magnetic Variation +/- (°)	NAV. Spec.
Hold	ESGOB	318	1 min.	L	3500	14000	230	+2	RNP

INSTRUMENT APPROACH CHART-ICAO
AD ELEV 159 FEET
HEIGHT RELATED TO THR RWY 23-ELEV 159 FT

TWR 119.85
121.70
APP 124.35

MATTALA/Mattala Rajapaksa Intl. Airport (VCRI)
ILS/DME RWY23

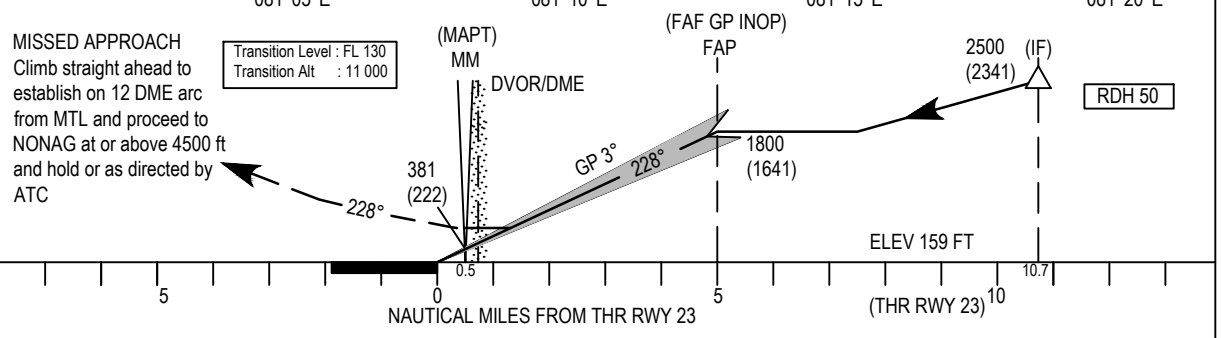
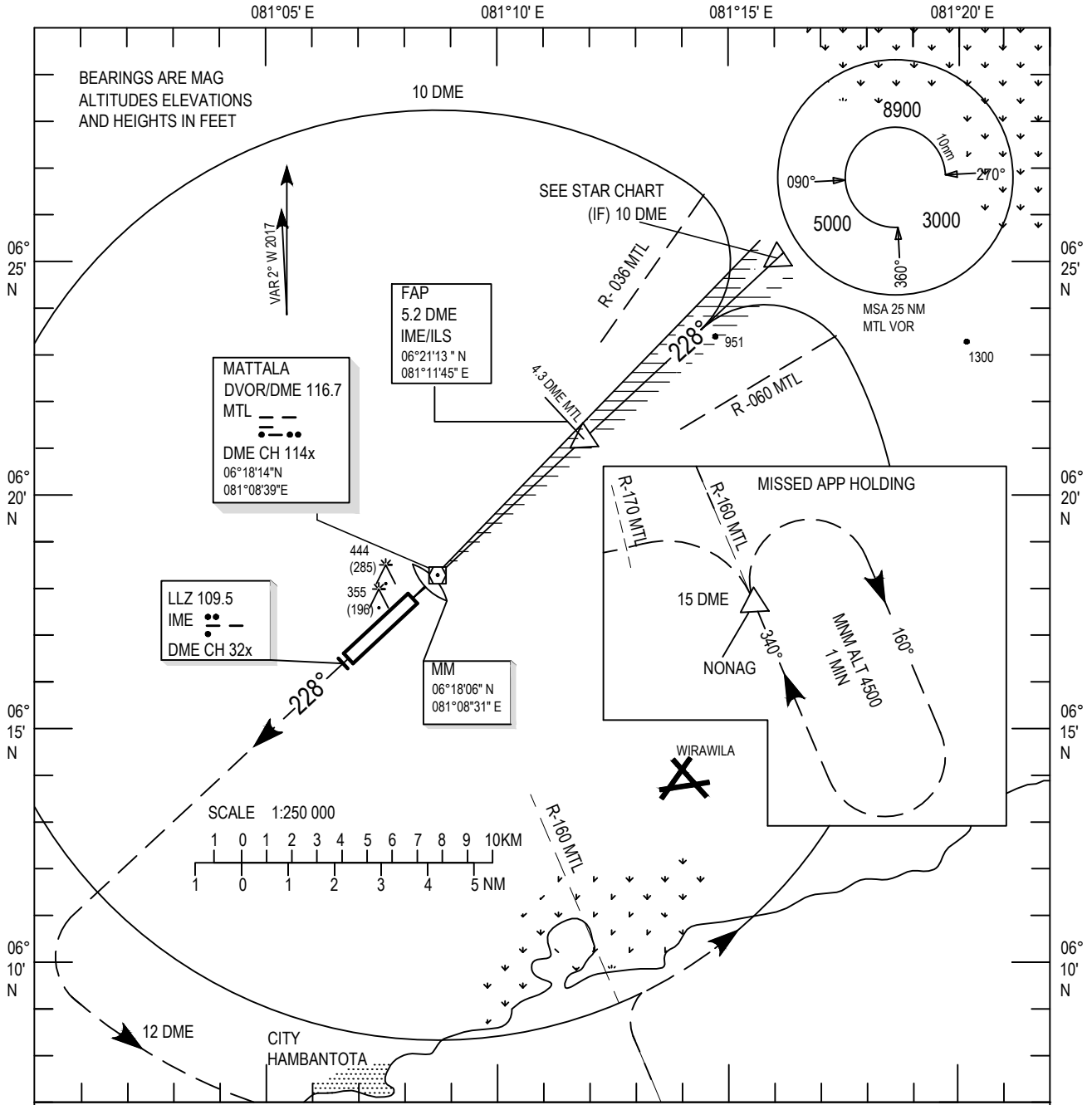

OCA(H)		A	B	C	D	Distance FAF-MM 4.5NM						
Straight-in	Cat I	290(130)	310(150)	310(150)	320(170)	GS	KT	100	150	200	250	300
	GP INOP	500(340)				TIME	min:s	2:41	1:47	1:20	1:04	0:54
						Rate of descent	ft/min	530	795	1061	1326	1591

INSTRUMENT
APPROACH
CHART-ICAO

AD ELEV 159 FEET
HEIGHTS RELATED TO
THR RWY 05-ELEV 136 FT

TWR	119.85
	121.70
APP	124.35

MATTALA/Mattala Rajapaksa
Intl. Airport (VCRI)

DVOR/DME RWY 05

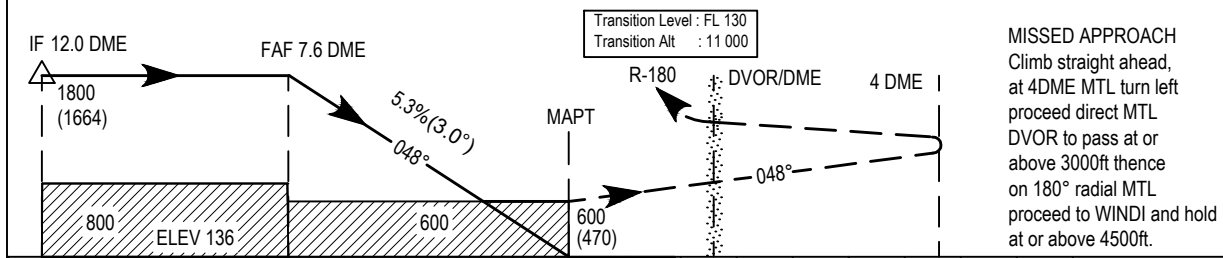
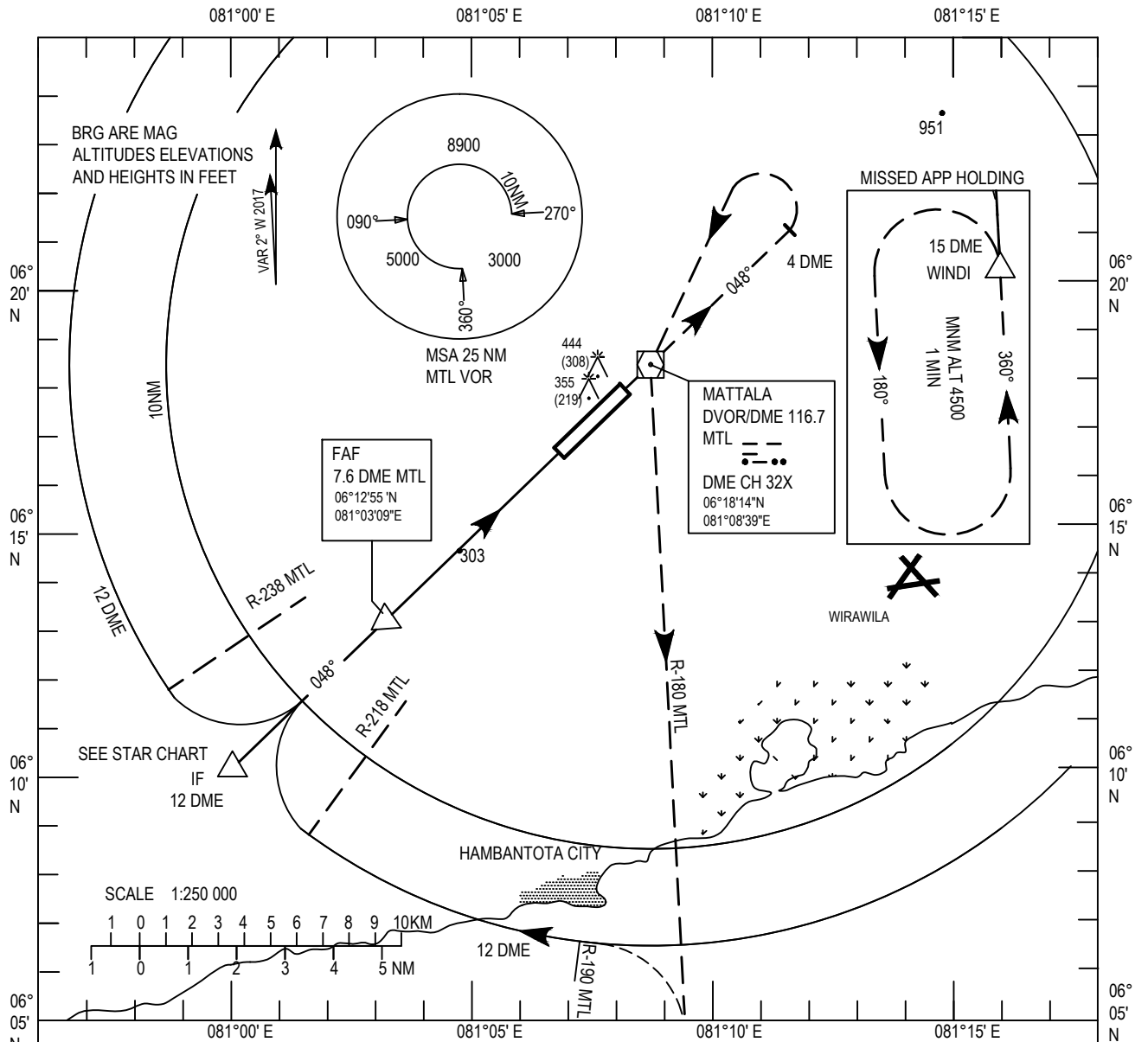

OCA/H	A	B	C	D	Distance DME MTL	6.6	5.6	4.6	3.6
Straight-in	600(464)				Altitude (Height)	1476(1340)	1154(1018)	831(695)	508(372)
					GS	100	150	200	250
					Rate of descent	539	808	1077	1346
						KT	150	200	250
						ft/min	808	1077	1346

INSTRUMENT
APPROACH
CHART-ICAO

AD ELEV 159 FEET
HEIGHTS RELATED TO
THR RWY 23-ELEV 159 FT

TWR 119.85
121.70
APP 124.35

MATTALA/Mattala Rajapaksa
Intl. Airport (VCRI)

DVOR/DME 23

